

# Fuel-efficiency technology trend assessment for LDVs in China: Advanced engine technology

**Authors:** Guowei Xiao, Zifei Yang, Aaron Isenstadt

**Date:** 17 September 2018

**Keywords:** engine technology, fuel efficiency, passenger car

## 1 Background

Fuel-consumption standards drive down China's use of fuel by the on-road sector and encourage the uptake of advanced vehicle-efficiency technologies. Understanding the need for a policy roadmap and long-term strategies to provide certainty for long-term fuel consumption, technology advancement, and potential compliance costs for manufacturers, China is looking ahead

to advance post-2020 standards for light-duty vehicles.

In its "Made in China 2025" strategic initiative (MIIT, 2015), China set a 2025 fleet efficiency target of 4 L/100 km for passenger cars, a 20% decrease from the 2020 target of 5 l/100km. In the Technology Roadmap for Energy Saving and New Energy Vehicles published by the Society of Automotive Engineers of China (SAE China, 2016), a 2030 fleet efficiency target

of 3.2 L/100 km was set. To evaluate whether and how these targets can be met, it is essential to understand what technologies will be available within the 2020-2030 timeframe and what the costs of applying those technologies in the Chinese market will be.

This series of technical briefings aims to provide a comprehensive understanding of the current availability, effectiveness, and future market penetration of key

### ABBREVIATIONS

<b>2-TCI</b>	Two stage turbocharger with intercooler	<b>CVVL</b>	Continuous variable valve lift	<b>IMA</b>	Integrated motor assist	<b>TCI</b>	Turbocharger with intercooler
<b>ACT</b>	Active cylinder technology	<b>DCP</b>	Dual cam phasing	<b>IMG</b>	Integrated motor generator	<b>VCM</b>	Variable cylinder management
<b>AFM</b>	Active fuel management	<b>DEAC</b>	Cylinder deactivation	<b>ISG</b>	Integrated starter generator	<b>VCR</b>	Variable compression ratio
<b>AGM</b>	Absorptive glass mat	<b>DLC</b>	Diamond-like carbon	<b>MDS</b>	Multi-displacement system	<b>VGT</b>	Variable turbine geometry turbocharger
<b>AVS</b>	Audi valve-lift system	<b>DSF</b>	Dynamic skip fire	<b>MPI</b>	Multi-point injection	<b>VT-C</b>	Variable compression ratio turbocharging
<b>BMEP</b>	Brake mean effective pressure	<b>DVVL</b>	Discrete variable valve lift	<b>NA</b>	Naturally aspirated	<b>VTEC</b>	Variable valve timing and lift electronic control
<b>BSG</b>	Belt-driven starter generator	<b>EGR</b>	Exhaust gas recirculation	<b>OHC</b>	Overhead-cam	<b>VVEL</b>	Variable valve event and lift
<b>CATC</b>	China automotive test cycle	<b>GDI</b>	Gasoline direct injection	<b>OHV</b>	Overhead-valve	<b>VVL</b>	Variable valve lift
<b>CCP</b>	Coupled cam phasing	<b>GSG</b>	Geely Stop-Go	<b>PFI</b>	Port fuel injection	<b>VVT</b>	Variable valve timing
		<b>HCCI</b>	Homogeneous charge compression ignition	<b>SCI</b>	Supercharger with intercooler		
		<b>ICP</b>	Intake cam phasing	<b>SI</b>	Spark ignition		
				<b>SPCCI</b>	Spark controlled compression ignition		

**Acknowledgments:** The authors thank the Energy Foundation China for sponsoring this series of studies. We greatly appreciate the generous contributions of time by the following experts: Ameya Joshi (Corning), Peter Davies, Ning He (Honeywell), Sean Osborne (ITB), Akichika Yamaguchi (Denso), experts from MAZDA, and John German (the ICCT).

fuel-efficiency technologies that manufacturers are likely to use in China by 2030. This information enables a more accurate, China-specific understanding of future technology pathways.

We group technologies into several categories: advanced engine, transmission, vehicle technologies, thermal management, and hybrids and electrification (Figure 1). The specific technologies we considered include those that are available today and others that are under development and expected to be in production in the next 5-10 years.

This research relies on information from publicly available sources, third-party databases, and information from the participating partners. Our approach includes:

- A detailed literature survey, including both Chinese and global regulatory documents, official announcements, and industry and academic reports.
- Analysis of databases from Polk and Segment Y.
- Conversations with manufacturers, tier one suppliers, research entities, and domestic and international experts.

For each key technology, we discuss how it reduces passenger-car fuel consumption, its effectiveness in reducing fuel consumption, and its current level of application or potential application in the China market. Wherever applicable, we compare technology trends in China with those in the United States and the European Union to reflect potential technology pathways in the long term.

This briefing assesses technology progress and new developments in internal combustion engines.

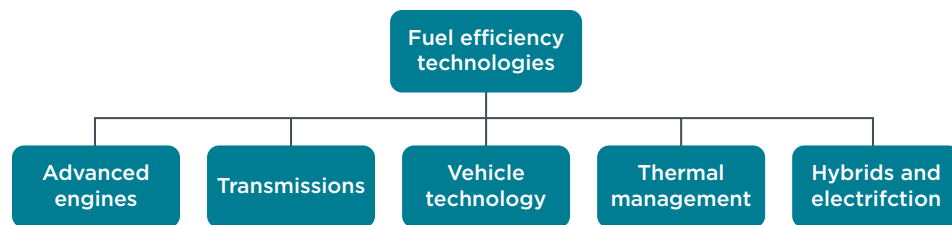

**Figure 1** Categorization of fuel efficiency technologies in the briefing

## 2 Introduction

Internal combustion engines convert the chemical energy in fuel into vehicle kinetic energy through specific thermodynamic cycles. The theoretical maximum efficiencies of the thermodynamic cycles indicate that not all the fuel's energy can be converted into vehicle movement. Indicated efficiency is defined as the proportion of fuel energy that gets transmitted to indicated work, or the work that the high-pressure in-cylinder gases do to the pistons during an engine's power stroke. Factors that affect an engine's indicated efficiency include incomplete combustion and wasted heat. Energy loss from incomplete combustion is negligible, but heat losses account for more than 60% of the fuel energy in current engines, half of which is wasted by the cooling system and half by exhaust gases. Moreover, not all the work done to the pistons makes it to final engine shaft output. This conversion rate is termed mechanical efficiency, since the losses are basically due to movement of other components. Factors that result in mechanical losses include pumping air into and out of the engine, friction, and powering accessories, such as the alternator, oil pump, water pump, and compressor for air conditioning. There are also idling losses, although not directly reflecting engine efficiency. These losses are highly dependent on the type of driving, so total losses can vary significantly.

Since about 1980, ongoing developments in computer-aided design and simulation, as well as on-board electronic controls, have enabled rapid technology improvement to reduce these sources of energy loss. These technologies not only improve engine efficiency but also reduce vehicle fuel consumption in other ways. For instance, apart from its benefits in heat losses and mechanical losses, turbo-downsizing can also reduce vehicle fuel consumption by simply reducing the weight of the engine and lowering engine speed. Stop-start technology reduces fuel consumption by shutting off the engine during idling. Some advanced stop-start techniques are also equipped with regenerative braking, which recovers energy from braking and uses it to power accessories, reducing accessory losses. In this section, we will evaluate technology progress and new developments of key technologies.

## 3 Current status

### 3.1 GASOLINE DIRECT INJECTION

Gasoline direct injection (GDI) injects highly pressurized gasoline into the combustion chamber of each cylinder. Since GDI provides direct cooling to the in-cylinder charge via fuel vaporization, it allows an increase in the compression ratio of approximately 0.5 to 1.5 points by improving knock resistance relative to naturally aspirated or turbocharged engines using port fuel injection (PFI)

(EPA, 2016a). In addition, the cooling effect results in more trapped intake charge, thus increasing engine volumetric efficiency and engine power and torque. GDI engines also improve exhaust scavenging at low engine speeds by increasing valve overlap and delaying fuel injection until after the exhaust valve is closed, further increasing engine power and torque at lower engine speeds. A study by Chang'an (Zheng et al., 2016) shows that, by replacing the multi-point injection (MPI) system of a 1.6L naturally aspirated 4-cylinder engine with a GDI system, fuel consumption was reduced by 3.9% over the New European Drive Cycle (NEDC) through increasing the compression ratio from 10.5:1 to 11.8:1. Furthermore, this replacement would increase engine torque by 5%-23% depending on engine speed, and maximum power by 4.5%. Some manufacturers are also pursuing dual injection by combining PFI and GDI.

In China, GDI penetration in the passenger car fleet has increased rapidly. Although market penetration estimates from different data sources vary (Figure 2), the rising trend is consistent. In 2016, the China Automotive Technology and Research Center (CATARC) estimated GDI penetration of 25% in China (CATARC, 2017) while IHS data showed 32%.

Based on the ICCT's analysis of Segment Y data, 87% of GDI applications in 2014 were on turbocharged engines. Most GDI installations in China are applied by joint venture OEMs. Independent manufacturers, such as Great Wall, Chang'an, and Chery, have also started to introduce GDI on passenger cars. For example, Great Wall's 1.5L turbo GDI (or 1.5T GDI) engine is already deployed in

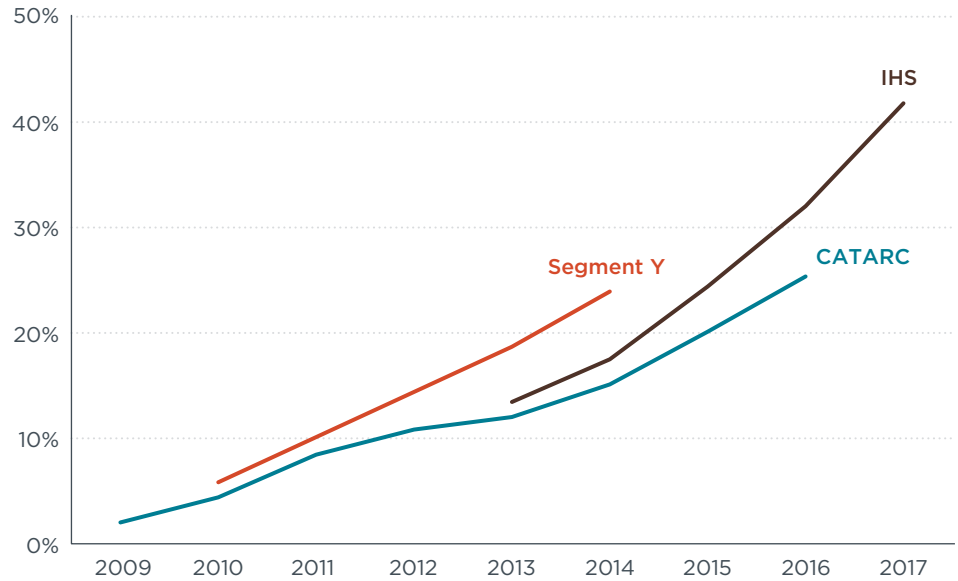

Figure 2 Market penetration of GDI from different data sources

the Haval H6 model; Chery's 1.6T GDI engine is expected to appear on the market in 2018; and in 2016 Chang'an introduced its Blue Core 1.5L turbo dual port injection (1.5 TDPI) engine, which combines GDI and PFI on a turbo engine (Chi, 2016).

The uptake of GDI is much higher in the United States. In model year 2016, 50% of new U.S. passenger cars used GDI, compared with 3.1% in MY2008. The projected 2017 GDI penetration in the United States is 54% (EPA, 2017). Unlike the Chinese market, more than half of GDI installations were on naturally aspirated engines (EPA, 2016b). The application of GDI on new gasoline vehicles sold in the European Union in 2016 was 44%.

In China, the main suppliers of GDI systems are United Automotive Electronic Systems Co. (UAES, a joint venture of Bosch and eight domestic OEMs or suppliers), Dongguan Keihin (a wholly owned subsidiary of Japanese Keihin), Delphi, and Denso.

### 3.2 COOLED EGR

Commonly used on diesel engines as a method to reduce emissions, cooled exhaust gas recirculation (EGR) has also been found effective for improving fuel efficiency of gasoline engines. EGR systems introduce some of the engine-out exhaust gas into the intake air stream, reducing combustion temperature by increasing the specific heat capacity of the in-cylinder gas. By lowering the combustion temperature and rate, EGR enables higher compression ratios, allows spark advance, reduces heat losses, and therefore reduces fuel consumption of both naturally aspirated and turbocharged engines. Cooling the exhaust before mixing it with the intake stream further exploits this technology's potential for improving engine efficiency. Cooled EGR also reduces fuel consumption by decreasing fuel enrichment, which is used to reduce exhaust gas temperature at high engine loads. On turbocharged engines, the lower combustion temperature also

results in higher turbo pressures and higher engine output, enabling further engine downsizing and downspeeding. The addition of inert exhaust gas to the intake system means that for a given power output, the throttle needs to be opened further, thereby reducing pumping losses at low engine loads. Various EGR strategies can be applied to the engine at different operating conditions to achieve optimum overall fuel economy.

According to BorgWarner, cooled EGR can reduce fuel consumption of a turbocharged GDI engine by 5%-8% (Zhou, 2014). Mahle Behr estimates this improvement to be 2%-5% (Morey, 2014). A study that applied cooled EGR on a 1.8L vehicle<sup>1</sup> increased the compression ratio from 10:1 to 10.8:1 and reduced average fuel consumption by 4.6% (Wang et al., 2016).

Cooled EGR is deployed on a variety of production models in the Chinese market. Like GDI, cooled EGR can be regarded as an underlying technology that typically combines with other technologies for lowering fuel consumption. Mahle Behr expects cooled EGR to be especially effective on downsized turbocharged engines and Atkinson-cycle engines used in hybrid vehicles. These engines are designed to run at higher loads and speeds, or in the operating region in which knock limit and mixture enrichment seriously affect fuel economy. The U.S. Environmental Protection Agency (EPA) conducted a benchmarking study on a 2.0L four-cylinder vehicle with a 14:1 geometric compression ratio and found a 6% reduction in fuel consumption under the U.S. CAFE test cycle (Schenk and Dekraker, 2016).

Application of cooled EGR in hybrid vehicles can be found in Toyota's lineup. Toyota's 2ZR-FXE engine, used in the fourth-generation Prius and Lexus CT200h, is characterized by a geometric compression ratio of 13.0:1, cooled EGR, and Atkinson cycle to reduce knocking. This engine realized a peak thermal efficiency of 38.5%. According to Toyota, the 8ZR-FXE is the domestic China model of the 2ZR-FXE, so it is believed that the domestic China Levin HEV and Corolla Hybrid also use cooled EGR as a method of improving fuel efficiency. Toyota also demonstrated ways to push thermal efficiency to 40% (Takahashi et al., 2015). One way is to expand the engine EGR rate limit, or the ratio between the recirculated exhaust gas flow rate and the total charge air flow rate, thus reducing heat and pumping losses. The drawback of a high EGR rate, however, is lower combustion speed. To improve combustion speed, the tumble ratio of this engine was increased from 0.8 to 3.5 by long stroke and straight intake. By those means, the new 2.5L I4 Dynamic Force engines, which appeared on the market in the 2018 Camry, realize a thermal efficiency of 41%. EGR usage has also been extended to non-hybrid vehicles with this engine, while the peak efficiency of the non-hybrid version is 40% (Toyota, 2016).

Application of cooled EGR in turbocharged engines is considered an option for current in-development turbocharged engines but has not yet been widely adopted. The EPA estimated the potential benefit of adding cooled EGR systems to conventional downsized turbo direct injection engines to be 3.6%. Mahle Behr tested two types of cooled EGR: a high-pressure system that diverts exhaust before it enters the turbocharger turbine, and a low-pressure system that diverts exhaust from downstream of the turbocharger

turbine. They found that the high-pressure EGR system reduced fuel consumption more at the highest engine speed and load—as much as 18%—while the low-pressure EGR system showed improvements over the entire engine road map and better average fuel economy (Morey, 2014). A test of high-pressure EGR on a 1.4T GDI engine by Tenneco Inc. demonstrated a 12% reduction in fuel consumption near peak power, and a fuel-economy improvement of 2%-3% was demonstrated by a simulation on the Worldwide harmonized Light Duty Test Cycle (WLTC) (Fischer, Kreutziger, Sun, and Kotrba, 2017).

Currently there is no application of cooled EGR in production turbocharged gasoline engines in China. Mazda's SKYACTIV-G 2.5T engine, which is applied on the CX-9, is an example of such application available in the global market. The engine features a compression ratio of 10.5:1. The use of high-pressure EGR in this engine improves knock resistance at high engine loads and allows the engine to maintain the ideal air-fuel ratio over a wider output range, thus reducing the need to retard ignition timing (Mazda, 2016).

In China, major suppliers of cooled EGR systems are Wuxi Longsheng Technology Co., Continental Automotive Systems US, and BorgWarner Automotive Components (Ningbo).

### 3.3 TURBO-DOWNSIZING

Compared with natural aspiration, turbochargers increase intake charge air density to raise the mass flow of air to the engine and thus require extra fuel to maintain stoichiometric conditions. These greater amounts of air and fuel increase engine power for a given engine displacement volume. Consequently, turbocharging allows an engine to be downsized while retaining

<sup>1</sup> The vehicle is equipped with multi-point injection, four cylinders, DOHC, and VVT and has a power of 101 kW.

the same level of performance. Given a constant power demand, a smaller-displacement engine operates at higher loads during normal driving conditions, resulting in lower pumping loss due to wider-open throttle and smaller heat loss. Smaller engines also have lower friction losses due to smaller cylinders and/or fewer moving parts. Turbochargers are driven by exhaust gas, so part of the wasted heat energy carried by the exhaust can be recycled. Turbo-downsizing also reduces the weight of the engine itself and its supporting mechanism. While this does not increase engine efficiency, it does decrease the work needed to move the vehicle, reducing fuel consumption.

Turbochargers are almost 100% accompanied by an intercooler to reduce the temperature of the intake air to increase charge density and reduce knock risk, making the most of the technology's benefits in fuel efficiency and power.

The benefit of turbo-downsizing in vehicle fuel consumption can be varied, depending on the boost level. The EPA and National Highway Traffic Safety Administration (NHTSA) considered three boost levels based on the engine brake mean effective pressure (BMEP), 18 bar, 24 bar, and 27 bar. These correspond to fuel-consumption reductions of 10.7%-13.6% at 18 bar, 15.0%-18.9% at 24 bar, and 16.4%-20.6% at 27 bar, depending on engine type. CATARC estimated the fuel consumption benefit of turbo-downsizing to be 7.2%. Based on this, we assume a 7.2%-13.6% fuel-consumption reduction benefit for this technology.

Even though gasoline turbocharged vehicles were introduced decades ago, it was not until recently that turbocharging and downsizing led to favorable market acceptance in

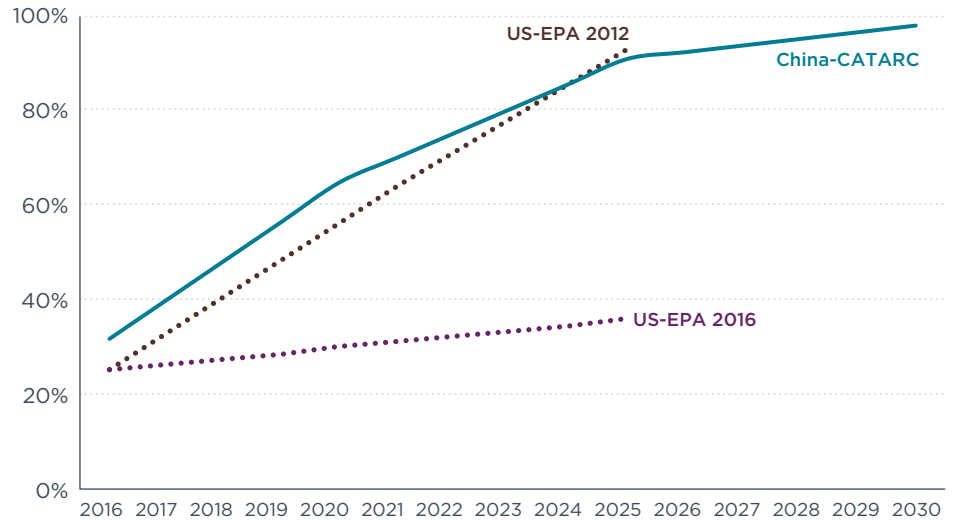

**Figure 3** Projection of turbocharging penetration in passenger car fleet in China and the United States.

China, Europe, and the United States. In China, turbocharger penetration in the passenger car fleet increased from 7% in 2010 to 21% in 2014 (Zhou and Yang, 2018) and to 32% in 2016 (CATARC, 2017). The vast majority of joint ventures—almost 95%—coupled turbochargers with GDI in 2014, while most independent automakers still apply turbochargers with PFI. The 1.5 TDPI engine used on Chang'an's new CX70T is one of the signs that independent manufacturers are introducing GDI technologies into turbocharged engines.

For comparison, in the United States, the gasoline turbocharged car market share was 23.8% in 2016 and increased to 30% in 2017. More than 60% of the gasoline turbocharged cars in 2016 were combined with four-cylinder engines, and more than 90% of gasoline turbocharged engines also used GDI (EPA, 2017).<sup>2</sup> Turbochargers are more prevalent in European countries, where the gasoline turbo-

charged car market share increased from 10% to 40% between 2010 and 2016. More than 90% of those gasoline turbocharged engines used GDI accompanied by downsizing (Wolfram and Lutsey, 2016).

In 2012, EPA/NHTSA projected that the future market penetration of turbocharging in the U.S. light-duty vehicle fleet would be 64% by 2021 and 93% by 2025 (EPA and NHTSA, 2012). But the estimate was revised down to 36% by 2025 in the EPA's latest evaluation reflecting improvement in other technologies (EPA, 2016a). Based on the model prediction of CATARC, 65% of the conventional passenger cars in China will have turbocharging and downsizing in 2020. That market share would increase to 91% in 2025 and 98% in 2030, according to the CATARC projections as shown in Figure 3.

In China, almost 100% of the applications of turbocharging in the passenger car fleet use single-stage turbo. Two or more stages of turbocharging and supercharging, which uses engine crank output to power the charger, are not mainstream in China. They

<sup>2</sup> GDI statistics also include light trucks, which are categorized as light-duty vehicles in the United States, with gasoline turbocharged engines.

account for just 0.1% of the passenger car fleet (Figure 4).

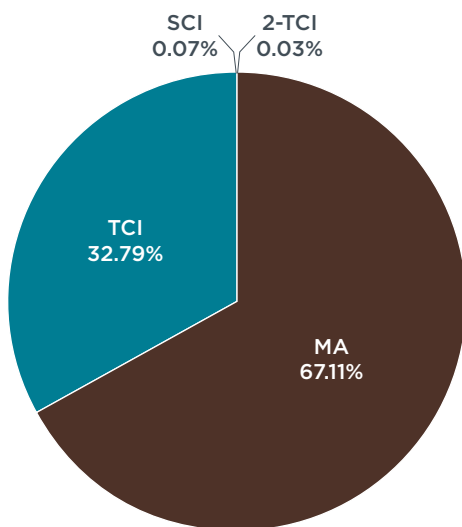

**Figure 4** Turbocharger distribution by type in 2016 in China (NA- naturally aspirated; TCI- turbocharger with intercooler; SCI- supercharger with intercooler; 2-TCI- two stage turbocharger with intercooler)

### 3.4 VARIABLE VALVE TIMING AND LIFT

Variable valve timing (VVT) and variable valve lift (VVL) offer greater control over the intake air and/or exhaust gases.

VVT alters the timing of valve opening and closing. It reduces pumping losses when the engine is lightly loaded by reducing the amount of valve overlap and increases power and torque when needed by increasing valve overlap.

Currently, cam phasing, which changes the phase angle of the camshaft with respect to the crankshaft, is the most commonly used form of VVT. There are three major types of VVT: intake cam phasing (ICP), coupled cam phasing (CCP), and dual cam phasing (DCP). CCP and DCP can modify the timing of both the inlet valves and the exhaust valves, but DCP is the most

flexible design, controlling intake and exhaust valves independently. Discrete cam-phasing VVT systems offer two or three discrete phasing angles, whereas continuous VVT can vary phase angle constantly. Compared with discrete VVT, continuous VVT greatly enhances engine flexibility. Continuous DCP system examples include Toyota's VVT-i system, BMW's Double-VANOS system, Nissan's C-VTC system, and Honda's i-VTEC. Today, all of Toyota's new passenger vehicles are equipped with a VVT-i system to enable control over intake and exhaust valve timing.

The majority of current cam phasing applications use hydraulically actuated units, powered by engine oil pressure and managed by a solenoid that controls the oil pressure supplied to the phasing system. Electric cam phasing, such as used by Toyota on the 2018 Camry, allows a wider range of camshaft phasing and faster time-to-position. The EPA estimated the benefits of VVT on fuel consumption to be 1%-5.5%, depending on VVT type and number of cylinders. CATARC also estimated the fuel-consumption reduction of VVT. Although they do not specify the VVT type and cylinder number, their prediction of a 2.18% reduction in fuel consumption is within the range estimated by the EPA.

VVT has now become a widely adopted technology. In China, VVT penetration in the passenger car fleet increased from 44% in 2010 to 64% in 2014. In 2014, 29% of passenger cars were equipped with intake VVT only, while 35% of passenger cars had VVT on both intake and exhaust valves. As a comparison, more than 98% of new passenger cars sold in the U.S. are estimated to use some form of VVT (EPA, 2016b). Generally, joint ventures had much higher adoption rates than independent manufacturers. Among the top-selling joint ventures,

Beijing-Hyundai, Dongfeng-Nissan, Shanghai-GM, Dongfeng-Yueda-KIA, FAW-Toyota, and Guangzhou-Honda equipped almost all of their passenger cars with VVT. The adoption rates of independent manufacturers increased from 7% in 2010 to 40% in 2014.

In addition to VVT which changes only the opening time of the valves, VVL enables variable valve lift and duration, offering greater control over engine air flow.

VVL changes the length and/or height of the valve opening. VVL control can further reduce pumping losses, increase engine power, and potentially reduce overall valve train friction (EPA, 2016a). VVL is normally applied together with VVT in China.

There are two major types of VVL: discrete VVL and continuous VVL. Discrete VVL (DVVL) switches between two or three discrete camshaft profiles to enable variable valve lifts. Pioneered by Honda in 1990, it is a mature technology with relatively low cost. Continuous VVL (CVVL) offers greater effectiveness since valve lift can be optimized for any engine load and speed. However, it is considered to be more complicated and costly. The EPA estimated that DVVL reduces fuel consumption by 2.8%-3.9% compared with VVT, while the benefits of CVVL were estimated to be 3.6%-4.9% compared with VVT. In China, VVL penetration in the passenger car fleet increased from 19% in 2010 to 64% in 2014 (Zhou & Yang, 2017).

Honda's VTEC (Variable Valve Timing and Lift Electronic Control) system is an example of DVVL technology. Currently all Honda passenger cars sold in China are equipped with this technology. The VTEC system features a locking multi-part rocker arm and two cam lobes/profiles, one optimized for low-speed fuel efficiency and the other

for high-speed performance. Switching between the two cam profiles is enabled by coupling or decoupling the rocker arms using a hydraulic system. Audi's AVS (Audi Valvelift System) is also a DVVL system but works in a different way. The system features two cam profiles and a single rocker arm. Switching between cam profiles is enabled by pushing the cam lobes to slide on the camshaft. In China, AVS appears in Volkswagen's EA888 engine, which is used by many passenger cars made by FAW-VW and Shanghai-VW, including the Magotan, CC, Tiguan, and Audi Q5 models.

Applications of CVVL come exclusively from joint ventures. Examples can be found in the passenger cars of BMW, Fiat, and Nissan. BMW's Valvetronic is the first mass-production CVVL system. It offers continuous and precise control over variable intake valve lift, from 0.3 to 9.7 mm<sup>3</sup>, and duration. Valvetronic cylinder heads use an extra set of rocker arms, called intermediate arms, positioned between the valve stem and the camshaft. These intermediate arms pivot on a central point by means of an extra, electronically actuated camshaft. This movement alone, without any movement of the intake camshaft, can vary the intake valves' lift from fully open, or maximum power, to almost closed, or idle (Boeriu, 2016). The Valvetronic system has been widely used by BMW. Application of this technology in the Chinese market can be found in Brilliance-BMW's 3 Series, 5 Series, and X1 models as well as in the imported 7 Series and X5, among others. PSA (including Chang'an DS, Dongfeng-PSA, and the imported PSA) also have a couple of models that use BMW's Valvetronic system.

Similar to Valvetronic, Nissan's Variable Valve Event and Lift (VVEL) is

an electric-driven CVVL system. A rocker and two types of links close the intake valves by transferring the rotational movement of a drive shaft with an eccentric cam to the output cam. The movement of the output cam can be varied by rotating the control shaft within the motor and changing the fulcrums of the links. This makes a continuous adjustment of valve lift possible (Nissan, 2008). VVEL was first introduced to the U.S. market in late 2007 on the 2008 Infiniti G37 Coupe equipped with the new VVEL VQ37VHR engine. It is available in the Chinese market on the Infiniti VQ37 3.7L V6 engine, used in the imported Infiniti Q50 and QX70, and on the VK56 5.6L V8 engine, used in the imported QX80.

In contrast to those electromechanical CVVL technologies, Fiat's MultiAir uses managed hydraulic fluid to provide variable valve control. The MultiAir system features a single camshaft that has three nodes per cylinder: two to actuate the exhaust valves and a single inlet cam which pushes a small pump that either opens the valves hydraulically or pushes the engine oil into a separate spring-loaded, high-pressure reservoir. An electrohydraulic actuator—a high-response, electronically activated solenoid—controls the pressure applied to hydraulic fluid, which is engine oil drawn from the sump, that fills a thin passageway connecting the intake valves and the camshaft. The solenoid valve regulates the amount of oil that is pumped by the cam action either to the valve or a bypass reservoir. When pressurized, the hydraulic line behaves like a solid body and transmits the lift schedule imparted by intake cam directly to the intake valve. When the solenoid is disengaged, a spring takes over valve actuation duties. This electrohydraulic link allows independent operation of the two components, which enables near real-time control over the valve

lift profiles. Whereas a closed solenoid transmits the pressure generated by the camshaft's intake profile to the valve in the normal fashion, an open solenoid breaks the hydraulic link between cam and valve, decoupling their operations (Ashley, 2010). This technology first appeared in the Alfa Romeo MiTo at the 2009 Geneva Motor Show. Currently, in the Chinese market, engines that have MultiAir applied are used on the imported Fiat 500 and GAC-FCA's Jeep Compass and New Cherokee.

### 3.5 CYLINDER DEACTIVATION

Cylinder deactivation (DEAC) keeps valves closed to disable or deactivate cylinders when the load is significantly less than the engine's total torque capability, thus reducing friction, heat losses, and pumping losses. DEAC reduces vehicle fuel consumption without sacrificing maximum power.

There are basically two types of cylinder deactivation technologies in the market. For overhead-cam (OHC) engines, the rocker arm has one part that follows the cam lobe and another that opens the valve. A latching or latching mechanism either connects or disconnects these two parts, thereby activating or deactivating the valves and their cylinder. For overhead valve (OHV) engines, a pushrod is used to connect the cam lobe and the rocker arm. Solenoids are used to release oil pressure in the tappet and to collapse the lifters and deactivate the pushrod and its respective cylinder.

The EPA estimated that DEAC would improve fuel economy by 0.5%-6.5%. The lower end of the estimate excludes the benefit of reduced pumping losses from advanced valve trains such as DCP and VVL. For baseline engines with no application of advanced valve train technologies, the benefit of DEAC would be

3 Valvetronic II and III offered 0.18 mm to 9.9 mm

4.7%-6.5%, depending on the number of cylinders, V6 or V8, according to the EPA. This estimate applies to OHC engines which are commonly used on passenger cars in China.

In MY2016, only 2% of the new passenger car fleet in the United States used DEAC. Light trucks had a higher DEAC penetration of 21%. In China, DEAC penetration in new passenger cars is not clear. There are a couple of examples of models, exclusively from joint ventures or importers, with DEAC in the Chinese market.

One is Honda's Variable Cylinder Management (VCM) system, which works by closing the intake and exhaust valves using its i-VTEC technology, an example of DEAC for OHC engines. The 3.0L i-VTEC V6 engine, which is specially designed for the Chinese market, can disable the three cylinders on the rear side and work in 3-cylinder mode during specific driving conditions—for example, highway driving. Currently, this engine is used on Honda's Crosstour and Acura's MDX and RDX models. It was also once used on Honda's Accord in MY2014-2015 but was discontinued in MY2016.

Examples of DEAC for OHV engines are GM's Active Fuel Management (AFM) system and Chrysler's Multi-Displacement System (MDS). GM's AFM was once used on the 2014 LaCross model. Chrysler's HEMI 5.7L V8 engine, which features MDS, can shut off four cylinders under light load to improve fuel economy. However, this engine was available only on the imported Chrysler 300C and Grand Cherokee in MY2005.

A DVVL system can also be used for DEAC if the low-lift cam lobe is modified to have a zero-lift profile. Used in Volkswagen's Active Cylinder Technology (ACT), this strategy deactivates two of the four cylinders at low

engine loads. The EA211 1.4T engine, which features ACT, can deactivate cylinders 2 and 3 when operating at part load. This engine is the first application of DEAC on a mass-produced I4 engine. However, the domestically produced EA211 engine does not feature ACT.

These technologies allow a fixed group of cylinders to be shut down. Thus, they normally are applied on larger engines with an even number of cylinders so that symmetrical cylinders can be deactivated to avoid intense torque fluctuations and vibration. As described in section 4.2, more-advanced DEAC technologies that allow variable cylinders to be shut down are being developed.

### 3.6 HIGH COMPRESSION RATIO

Increasing the compression ratio of naturally aspirated engines improves thermal efficiency. However, doing so also increases the risk of knocking, or the abnormal combustion phenomenon in which the air/fuel mixture ignites before the flame front arrives because of high pressure and temperature. This leads to reduced efficiency and engine power. Manufacturers need to resolve the higher risk of knocking associated with high compression ratios.

Mazda's SKYACTIV-G engine achieved one of the highest compression ratios among mass production vehicles (Mazda, 2010). The advertised geometric compression ratio was 14.0:1 in the European Union and 13.0:1 in the United States and China, reflecting a relatively lower fuel octane value. In the case of the SKYACTIV-G engine, the Atkinson cycle concept and direction injection are used. Atkinson cycle is enabled by delaying intake valve closing by the dual VVT system, which reduces

pumping losses by 20% (Isenstadt, German, and Dorobantu, 2016).

An effective way to decrease the risk of knocking is to reduce the amount of hot exhaust gas remaining inside the combustion chamber, lowering the gas temperature at the end of the compression stroke. Mazda made significant efforts to reduce the risk of knocking at high compression ratios. First, a fabricated 4-2-1 exhaust manifold reduces the amount of exhaust gas that flows backward into one cylinder from another. Second, a combustion chamber optimized with high-tumble flow and a small bore, together with other improvements such as increased injection pressure and split injection, creates a more homogeneous air/fuel mixture, and as a result, shortened combustion duration, which also decreases the risk of knocking. Third, a piston cavity improves combustion stability by preventing the initial flame from contacting the piston head.

Combining increased compression ratio with the other improvements discussed, Mazda realized a 15% increase in fuel efficiency under JC08 test cycle and an increase of 15% in torque.

The SKYACTIV technology was introduced in Japan in 2011 on the Mazda 2 and in the United States in 2012 on the CX-5 and Mazda 3. The SKYACTIV engine was first introduced to China in 2012 on the imported CX-5. Starting in 2013, the CX-5 with a SKYACTIV engine was domestically manufactured in China. Subsequently, the SKYACTIV engine was applied on the Atenza of FAW-Mazda, the Axela of Chang'an-Mazda, and the CX-4 of FAW-Mazda. Currently, all of Mazda's passenger vehicles in China use SKYACTIV engines.

Beside Mazda, Toyota's newly developed Dynamic Force Engine has a



high compression ratio of 13:1 (Toyota, 2018). It is deployed on the 2019 Corolla but has not been introduced to China yet.

### 3.7 ATKINSON CYCLE

Adopting alternative thermodynamic cycles is another method to improve thermal efficiency. Compared with the conventional Otto cycle, the Atkinson cycle enables an expansion ratio higher than the compression ratio. This allows more work to be extracted per volume of fuel/air mixture by allowing the combustion gases to expand beyond the point at which compression begins. When applied to modern naturally aspirated engines, the Atkinson cycle is realized by delaying intake valve closing. This results in an effective compression ratio lower than the expansion ratio during the power stroke and allows the geometric compression ratio to be increased. Because Atkinson cycle engines need to adjust the intake valve timing, they require VVT to optimize the effective compression ratio. Although the higher expansion ratio improves fuel efficiency, Atkinson cycle engines sacrifice some maximum power, since part of the charged air is pushed out by the piston during the compression stroke of the engine. To retain vehicle performance, older Atkinson-cycle engines generally increase displacement or are paired with a full-hybrid system, where the electric motor returns the power to an equivalent level of performance by adding additional torque. However, the performance limitations are being overcome by newer designs that include cooled EGR and wider VVT operating ranges, such as the base engine in the 2018 Camry which increased power

by 8% over the same size engine in the previous Camry (German, 2018).

Hybrid systems of joint ventures, such as those of Toyota and Ford, use the Atkinson cycle to achieve improved efficiency. Toyota's 1.8L 8ZR-FXE engine, used on GAC-Toyota's Levin HEV and FAW-Toyota's Corolla Hybrid in MY2018, is equipped with Toyota's VVT-i to allow flexible intake valve closing time, with a geometric compression ratio of 13.0:1. It should be noted that because of delayed intake valve closing, the effective compression ratio is lower than the geometric compression ratio, thus reducing the risk of knocking. Independent manufacturers are also starting to apply Atkinson cycle engines to hybrid vehicles. For example, GAC announced the GS4 PHEV and GA3S PHEV models in 2018, both of which are equipped with a 1.5 ATK Atkinson engine.

Atkinson-cycle engines on non-hybrid vehicles are usually combined with high compression ratios. One example is Mazda's SKYACTIV-G naturally aspirated engine, which was introduced to China in 2012. In the SKYACTIV-G engine, the switch between Atkinson cycle and conventional Otto cycle is enabled by Mazda's Dual S-VT, a VVT technique. The conventional Otto cycle was used at high engine load for performance and the Atkinson cycle was used at part load for efficiency.

As modeled by the EPA, the application of Atkinson cycle could reduce CO<sub>2</sub> emissions by 3%-8%, which includes the effects of high compression ratio and cooled EGR (EPA, 2016a). However, analysis by the ICCT, which takes the recent progress of OEMs into consideration, suggests

this benefit to be 10%-14% (Lutsey et al., 2017).

### 3.8 STOP-START

A stop-start system temporarily stops the engine when the vehicle stops and restarts it when acceleration is needed, thus reducing fuel consumption during idling time in urban driving. The China Automotive Test Cycle (CATC), which reflects general driving conditions in China, includes an idling time of 22% (Li, 2018), longer than the 13% idling time on the WLTC and the 19% idling time on the U.S. FTP cycle. Given the long idling time of vehicles when driving in cities in China, stop-start is an effective technology for reducing real-world fuel consumption.

In 2016, around 8% of new vehicles sold in China had stop-start systems, up from 1.8% in 2012 (Zhao, Wang, Qu, and Ren, 2015; Sun, 2017). In MY2016, 9.1% of new passenger cars in the United States had stop-start (EPA, 2016b). The technology is highly adopted on EU cars with 63% penetration in 2016.

There are generally two types of stop-start system available in the market: reinforced starter systems and direct starter systems. Both can be combined with a limited amount of regenerative braking, sometimes referred to as a micro-hybrid. Mild and full hybrid propulsion systems are not included in this paper but are introduced in the papers in this series on hybrids and electrification technology.

**Reinforced starter** systems are the simplest and most widely adopted stop-start system. The main component is a more robust starter that can withstand the increased number of engine starts and a more capable battery that can meet the heavier power drawn by vehicle accessories

with the engine off. The EPA estimated that the potential reduction in fuel consumption with reinforced starter systems would be 1.8%-2.4%. CATARC estimated the benefit to be 3.5%. These are close to each other, and considering the longer average idling time on the China test cycle, it's reasonable to expect a larger benefit in China. The problem with reinforced starter systems, however, is discomfort for passengers caused by frequent rough restarts.

Typical reinforced starter systems include Valeo's ReStART, Bosch's Efficiency Line products, and Denso's Enhanced Starter products. The Valeo system is used by Citroën, Peugeot, Smart, Land Rover, and Volvo, while the Bosch system is used by Volkswagen, BMW, Nissan, and Fiat. Independent manufacturers, such as Geely, Great Wall, and Chang'an, also apply stop-start technology. The Geely Stop-Go (GSG) system first appeared in the EC7 GSG sedan in 2012. Chang'an STT system, which uses Bosch's solution, also first appeared in 2012 in the Eado sedan.

Stop-start is expected to develop rapidly in China. On May 2, 2017, Zhengzhou Coal Mining Machinery Group Co. (ZMJ) teamed up with the Hong Kong-based private equity firm China Renaissance Capital Investment and bought Robert Bosch Starter Motors Generators Holding GmbH (SG) from the German group (Meng & Shi, 2017). Bosch has been the major stop-start system supplier providing 95% of the start-stop systems used on Chinese cars in 2014 (Zhan, 2014). The chairman of ZMJ predicted that stop-start system penetration would rise to about 60% by 2020, much higher than Bosch's 2013 estimate of 30% by 2019 (Meng and Shi, 2017; ChinaEV, 2013).

**Direct starter** systems restart the engine through combustion, rather than relying on a starter motor. Mazda is the only manufacturer that employs direct starter, the i-STOP system. During engine shutdown the piston positions are precisely controlled, and during restart fuel is injected into the appropriate cylinder and ignited to generate downward piston force and restart the engine. Mazda asserted a reduction of about 8% in fuel consumption under the JPO8 test cycle (Mazda, 2009). Currently, all of Mazda's passenger vehicles in China are equipped with an i-STOP system.

When supplemented by regenerative braking technology, a stop-start system of either type is sometimes referred to as a micro-hybrid system. By using recovered braking energy to power the electronic systems and engine accessories, regenerative braking can reduce the load placed on the engine by the alternator and therefore provide additional benefits in reducing fuel consumption. Many different types of regenerative braking are being developed. BMW's Efficient Dynamics uses the alternator to recharge the battery when decelerating or braking. The battery experiences very different load characteristics from a normal car battery, thus BMW uses an absorptive glass mat (AGM) lead-acid type of battery. Mazda's i-ELOOP, produced in 2014, uses an ultra-capacitor to capture braking energy and provide power for conventional vehicle electronic systems. When used in conjunction with Mazda's i-STOP, the company reports fuel savings of as much as 10% in real-world driving conditions with frequent acceleration and braking (Mazda, 2011). The Mazda i-ELOOP and Valeo iStars system are considered micro-hybrid systems (German, 2015).

### 3.9 ENGINE FRICTION REDUCTION

Engine friction reduction technologies can be categorized into low-friction lubricants and engine friction loss reduction. CATARC estimated that friction reduction technologies in total would reduce fuel consumption by 3.5%.

Low-friction lubricants include low-viscosity and advanced low-friction lubricant oils. If manufacturers make use of these lubricants, they may need to make engine changes and conduct durability testing to accommodate the lubricants. Consequently, cost increases include the costs of lubricants, engine changes, and testing.

Technologies to reduce engine friction losses include low-tension piston rings, roller cam followers, improved material coatings, more-optimal thermal management, piston surface treatments, and other improvements in the design of engine components and subsystems that improve the efficiency of engine operation. For example, Nissan first coated the valve lifter with diamond-like carbon (DLC) on its VQ engines and reduced friction by around 40% (Nissan, 2006). A Chinese study looking at reducing piston and valve friction by applying DLC film coating found a 3 N·m torque reduction and a 2% decline in fuel use on a 1.8L vehicle<sup>4</sup> (Wang, Huang, and Huang, 2016). Federal-Mogul Powertrain introduced a new generation of its coating technology, Ecotough, in 2017, delivering reductions in piston friction of as much as 15% and reducing fuel consumption by 0.8% compared with standard coatings (Federal-Mogul Powertrain, 2016). Chery's third-generation

<sup>4</sup> The vehicle is equipped with multi-point injection, 4 cylinders, DOHC, and VVT and has a power of 101 kW.

engines, released in 2017, lowered engine friction by 20% compared with the preceding generation by improving the lubricant system and design of the valve timing system, crank connecting rod accessory system, and cooling system, according to the company (Chery, 2017).

This study does not have detailed information on the adoption of friction reduction technologies in the Chinese passenger car fleet. In the technology roadmap drawn by SAE China (SAE China, 2017), the goal is to develop 0W-20 lower-viscosity oil by 2020 and to realize scaled application of 5W-20 or 0W-20 oil by 2030. The EPA estimated that the penetration of such low-friction lubricants among light-duty vehicles would exceed 85% by MY2017 and reach nearly 100% in MY2025. The penetration of technologies to lower engine friction losses would exceed 70% by MY2017, according to the agency (EPA, 2012).

### 3.10 SUMMARY

Table 1 summarizes the contribution to reducing fuel consumption by each of the technologies discussed, based on different sources.

## 4 Improvements under development

There are a variety of advanced engine technologies that have potential to further reduce fuel consumption of passenger vehicles. Some are already applied on vehicles in other countries; some will soon enter the Chinese market according to manufacturers' public announcements; and some are still under development. None of these technologies has yet entered the Chinese market, but most of them have the potential to be applied on cars sold in China in the near future.

**Table 1** Technology penetration and fuel consumption reduction summary

Technology		Penetration in Chinese passenger car fleet	Estimated fuel consumption reduction (U.S.) <sup>a</sup>	Estimated fuel consumption reduction (Chinese sources)	
GDI		25.3% (2016) <sup>b</sup>	1%-3%	4.5% <sup>b</sup> ; 3.9% <sup>c</sup>	
Cooled-EGR		n/a		3.63% <sup>b</sup> ; 4.6% <sup>d</sup>	
Turbo-downsizing		32% (2016)		7.20% <sup>b</sup>	
VVT	ICP	33% (2014)	2.1%-2.7%	2.18% <sup>b</sup>	
	CCP	31% (2014)	1%-3%		
	DCP		4.1%-5.5%		
VVL	Discrete	62% (2014)	2.8%-3.9%		
	Continuous	2% (2014)	3.6%-4.9%		
DEAC		n/a	0.5%-6.5%	0.44% <sup>b</sup>	
High compression ratio		1% (2014)	3%-8%		
Atkinson cycle			8.0%-10.3%; 10%-14% <sup>e</sup>		
Stop-start	Reinforced starter	8% (2016)	1.8%-2.4%	3.5% <sup>b</sup>	
	Direct starter	1% (2014)	8% (JC08)		
Friction reduction	Surface coatings			3.54% <sup>b</sup>	2% <sup>d</sup>
	Others		0.8% (level 1 lubricants)		

<sup>a</sup> EPA and NHTSA, 2012

<sup>b</sup> CATARC, 2017

<sup>c</sup> Zheng et al., 2016

<sup>d</sup> Wang et al., 2016

<sup>e</sup> Lutsey et al., 2017

### 4.1 HCCI

Homogeneous charge compression ignition (HCCI) is an engine combustion concept that works by using compression, rather than a spark, to ignite a homogeneously premixed air/fuel mixture. This technology promises significant fuel-economy benefits, which come primarily from a combination of highly lean operation and a resulting high specific heat ratio and reduced pumping losses, typically higher compression ratio, and shorter combustion duration.

Although there is extensive understanding of HCCI combustion, controlling the ignition timing is extremely challenging. It is difficult to prevent explosive combustion at high engine loads due to excessive dense fuel

and to prevent misfire at low engine loads. Thus, the operating range of conventional HCCI is has been limited to a small region on the engine map. However, Mazda has addressed these issues and expanded the operating range for its second-generation SKY-ACTIV gasoline engine (SKYACTIV-X) launching in 2019, which uses super lean-burn compression ignition (CI) with a high compression ratio of around 15:1.

The SKYACTIV-X engine uses a spark plug to achieve complete control of CI combustion. For this reason, Mazda terms the technology Spark Controlled Compression Ignition, or SPCCI. With spark control, the operating range of CI combustion is greatly expanded, and the engine achieves stable switching between

CI and spark ignition (SI). At low to medium engine speeds, the engine works in lean-burn CI mode. In this mode, the spark plug ignites the homogeneous air/fuel mixture, forming an expanding fireball, which additionally compresses the air/fuel mixture outside the fireball. At high engine speeds, the engine works in SI mode, with the spark plug as the only ignition source (Figure 5).

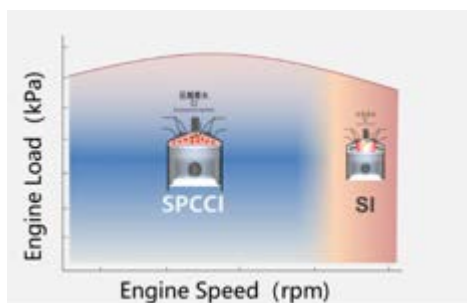

Figure 5. SPCCI operating range (provided by Mazda)

A highly responsive air supply unit and EGR allow full control of the in-cylinder gas composition, enabling optimized CI. By combining these improvements, Mazda reports that the SKYACTIV-X engine achieves a 20%-30% reduction in fuel consumption on the WLTC, as well as a 10%-30% increase in engine torque using RON 91 gasoline, as compared with Mazda’s current SKYACTIV gasoline engine (Mazda, 2017). Additional costs of the SKYACTIV-X engine include a highly responsive supercharger for the air supply, high-pressure fuel injection system, and in-cylinder pressure sensors.

According to Mazda’s market strategy, vehicles using SPCCI technology would appear in China in 2019 or a little later. In a technology roadmap drawn by SAE China (SAE China, 2017), average thermal efficiency of PV engines is expected to increase to 40% by 2020, 44% by 2025, and 48% by 2030.

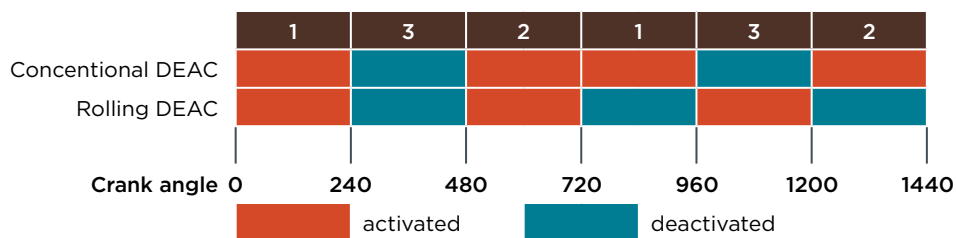

Figure 6. Firing orders of conventional DEAC and rolling DEAC

Among the proposed technologies, HCCI combustion is regarded as one promising way to improve engine efficiency. Domestic OEMs are advised to invest in HCCI from the year 2018 and are expected to apply it on gasoline engines from 2023.

#### 4.2 ADVANCED CYLINDER DEACTIVATION

As discussed, conventional cylinder deactivation technologies allow certain cylinders to be shut down, normally applying to larger engines with an even number of cylinders to avoid intense torque fluctuations and vibration. Dynamic cylinder DEAC, however, can continually change the active cylinders, therefore offering the capability of reducing engine noise, vibration, and harshness (NVH) by controlling the firing order and firing density, or the ratio of cylinders actually fired to the maximum possible. This expands the operating range, approximately doubling the efficiency benefits, and extends the range of applicability to smaller engines.

Ford is planning to apply DEAC technology to its 1.0L I3 EcoBoost engines, which will be used on Focus and Fiesta ST models in the European Union in MY2018. This would be the first application of DEAC on an I3 engine, although it is a fixed rather than dynamic form of DEAC. By applying a switchable roller finger follower deactivation mechanism to one cylinder, this technology will enable the 1.0L I3

engine to operate in 666 cm<sup>3</sup> twin-cylinder mode when cruising. The general DEAC system is complemented by a specially developed pendulum absorber as well as a Schaeffler dual-mass flywheel and a tuned clutch disc to achieve vibration isolation between transmission and engine, thus mitigating the NVH effects. Ford reported a reduction in fuel consumption of 4%-6% in a Focus operating in twin-cylinder mode (Birch, 2015).

Ford is also researching a rolling, or dynamic, form of DEAC on the same 1.0L I3 EcoBoost engine (Birch, 2015). The fixed deactivation strategy effectively improves fuel efficiency but has the disadvantage of an uneven firing sequence. By applying the DEAC mechanism to all three cylinders, the rolling cylinder deactivation can vary the number and sequence of deactivated cylinders as shown in Figure 6. Such a strategy effectively runs the engine in half-engine mode, corresponding to a 500 cm<sup>3</sup> engine with the advantage of an even firing order.

According to Ford, the rolling DEAC strategy has the potential of further reducing pumping losses at very low loads, resulting in better fuel economy during low-load drive cycles. The overall load limit of this half-engine mode would be lower than the twin-cylinder fixed DEAC mode. Ford reports a 1.2% fuel-efficiency benefit on the NEDC compared with the improvement already achieved with the fixed-cylinder DEAC for the 1.0L Fiesta engine.

For the larger Mondeo model using the same engine on the WLTC, however, the gain would be negligible.

Delphi and Tula have jointly developed a dynamic DEAC technology called Dynamic Skip Fire (DSF). Similar to Ford's solution, DSF also deactivates a cylinder using a switchable roller finger follower mechanism. However, a different controlling strategy is applied. During DSF operation, the decision to fire or skip a cylinder is made right before each ignition event, based on the torque demand and avoiding known resonance patterns within the engine (Birch, 2017). By choosing the right firing density, the DSF controller can effectively keep the activated cylinders running at optimum efficiency and reduce throttling losses at low engine loads (Tula, 2015). Delphi reported a fuel-economy improvement of 10%-20% compared with conventional engines, depending on the engine and driving conditions (Delphi, 2015). DSF has been demonstrated on a Volkswagen 1.8-L TSi engine.

GM is introducing the world's first production dynamic DEAC system on the redesigned 2019 full-size pickup trucks in the United States. This is based upon the Delphi/Tula system.

Cylinder DEAC for smaller engines and dynamic DEAC are expected to expand into additional production within a few years. However, it is difficult to estimate the benefit of this technology as it is highly dependent on the existing valve train configuration and adopted efficiency technology of the baseline engine. Ford and PSA estimated the additional benefit of dynamic DEAC to be 1%-2% over conventional fixed-cylinder DEAC. The ICCT estimated the benefit to be 2.5%-3.0% over fixed DEAC with greater benefits for smaller engines over the U.S. driving cycles (Lutsey, 2017).

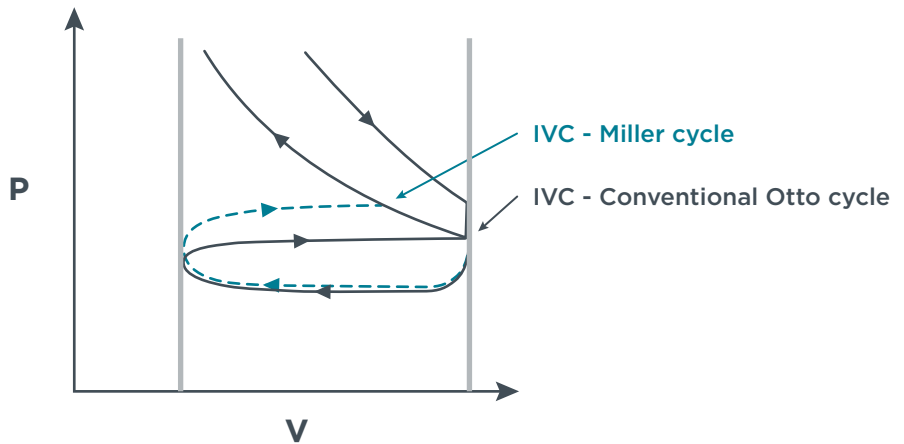

**Figure 7.** Miller cycle early Intake Valve Closing (IVC), V - in-cylinder volume, p - in-cylinder pressure

### 4.3 VARIABLE GEOMETRY TURBO

The vast majority of turbocharged engines in China's passenger vehicle fleet today apply a fixed geometry turbo with a waste gate to reduce the maximum boost pressure.

Variable Turbine Geometry Turbochargers (VGTs, also known as variable nozzle turbines—VNTs) are a type of turbocharger that exhibits increased efficiency over a wide range of flows, enabling better transient response and reduced lag compared with fixed geometry turbos. The aspect ratio of VGTs can be varied by altering the geometry of the turbine housing based on the engine operation condition. At low engine speeds, the aspect ratio can be decreased to allow a lower boost threshold and reduced lag, while at high engine speed the aspect ratio can be increased to avoid exhaust choking. A study has shown that, compared with conventional turbochargers, VGTs can increase boost pressure by 30% and reduce backpressure by 10% (Li, 2013).

While VGTs have been developed for diesel engines, until recently they were not applied to gasoline engines as the exhaust temperatures were

too high. Recent advances in material technology have improved the turbo's ability to withstand high-temperature oxidation and wear resistance, and cooled EGR is reducing exhaust temperature. Consequently, VGTs have started appearing in gasoline engines, especially in sports cars such as the Porsche 718 Boxster.

In 2016, Volkswagen announced the new 1.5L TSI EA211 Evo engine, the first mass-production gasoline engine with VGT. This engine is expected to be used in various VW and Audi models, including the new seventh generation Golf. The major improvement of this engine over its predecessor is use of the Miller cycle and a high geometric compression ratio of 12.5:1. Similar to the Atkinson cycle in naturally aspirated engines, the Miller cycle is enabled by advancing the closing time of the intake valve, as shown in Figure 7. As a result, the charged gas expands and cools during the later part of the intake stroke, which places a crucial responsibility on the turbo to provide external compression. This is equivalent to shifting some of the compression work to the turbocharger, so the engine operates with higher thermal efficiency. Use of VGT is critical in enabling the Miller cycle as it increases the turbo's ability

to satisfy the needs of a Miller-cycle engine across a broader operating range, while the Miller cycle reduces exhaust temperatures, allowing the use of VGT. Compared with its predecessor, the 1.5L TSI EA211 engine is represented as providing a 10% efficiency improvement as well as a 5%-10% reduction in fuel consumption over most of the engine map (Volkswagen, 2016).

Generally, the Miller cycle is estimated to add an additional 5% efficiency improvement over conventional waste gate turbo-downsizing, while the application of VGT can add an additional 1% (Isenstadt et al., 2016). As a result, a Miller cycle engine with VGT is estimated to reduce engine fuel consumption by 12.7%-18.7%, and without, by 11.8%-17.9%.

Although there is yet no volume application of VGTs in China's passenger fleet, some independent Chinese OEMs are exploring VGTs and starting to develop their own Miller-cycle engines to comply with the new Chinese fuel-economy legislation, according to Honeywell.

#### 4.4 ELECTRIC BOOSTING

Another improvement considered effective in reducing fuel consumption in turbo-downsized engines is an electric boosting, or e-boost, system. With stricter CO<sub>2</sub> limits, 48V systems are expected to be more popular and give e-boost an opportunity to further improve vehicle performance and reduce CO<sub>2</sub> emissions. By solving problems with turbo lag, e-boost enables additional engine downsizing and downspeeding. E-boost is estimated to add fuel consumption benefits of 2%-5% over conventional single-stage turbocharging, which translated to a 7.4%-17.9% efficiency improvement over a conventional

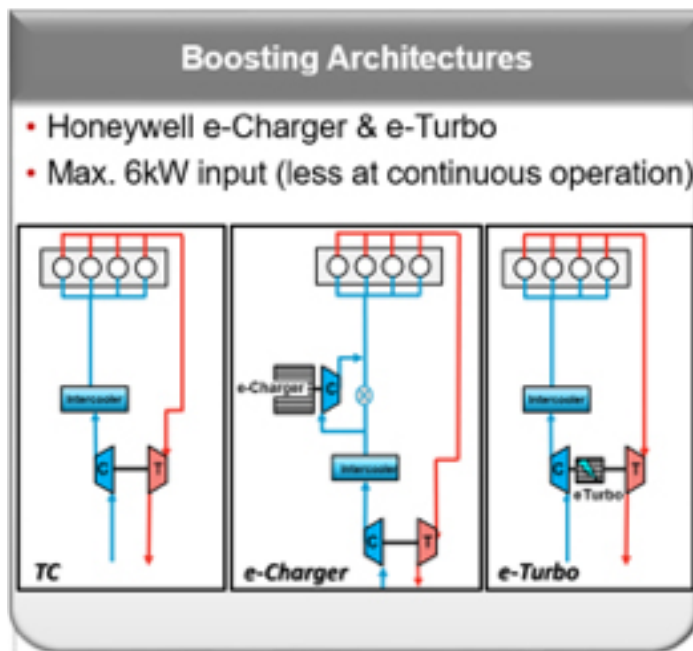

**Figure 8** Boosting Architectures (provided by Honeywell)

naturally aspirated engine (Isenstadt et al., 2016).

There are two basic forms of electric boosting architectures: turbo plus an electric compressor (eCharger) or electric turbo (eTurbo) only (Figure 8). Both eCharger and eTurbo give excellent transient performance, while it's broadly accepted that eCharger offers the best steady-state low-end performance.

##### 4.4.1 eCharger

ECharger can be considered like a two-stage turbocharger system. With electric motor help, traditional turbo lag is minimal. For performance cars, eCharger also supports additional low-end torque. If combined with a gear-shifting strategy, early gear shifting can also reduce CO<sub>2</sub> emissions.

##### 4.4.2 eTurbo

Miller valve timing is well known for its ability to improve fuel economy

thanks to increasing the geometric compression ratio of an engine. In gasoline engines, another benefit is enhanced knock resistance, which allows the re-phasing of combustion and further improved thermodynamic efficiency. This requires the turbocharger to provide more boost without demanding higher back-pressure in areas of the map where the Miller timing is to be exploited. The bigger challenge is to maintain the engine transient response at an acceptable level (Pohorelsky, Vondrak, Chobola, Jeckel, and Davies, 2018).

Electrically assisted turbochargers also have the functionality to recover energy from the exhaust stream instead of opening the waste gate to control speed and boost. This process is typically referred to as recuperation. Recuperated electrical energy may be used directly by loads on the vehicle electrical network, or be stored in the battery if the state of charge permits.

ETurbo gives the system more flexibility to manage energy from exhaust manifold.

RTS 95 driving cycle simulations confirm that it is possible to save 1.5%-3.5% of fuel (Pohorelsky et al., 2018). The technology is demonstrated on the Audi Q7 (Figure 9) and is very likely to come into production in 2021 in the C, D, and SUV segments with 1.5L and 2.0L applications.



**Audi Q7, 2.0l Gasoline**

- 215kW with full  $\lambda=1$
- Faster transient

**Honeywell Boosting**

- 48V e-Turbo with Advanced Compressor
- GT 25

**Figure 9** Application of e-Turbo on demo vehicle

**4.5 VARIABLE COMPRESSION RATIO**

Increasing the compression ratio is a straightforward way to improve the thermal efficiency of an engine. Variable compression ratio (VCR) systems change the compression ratio of the engine based on the operating condition—increasing it at low engine load to promote thermal efficiency, and decreasing it at high load to reduce knock risk and improve engine performance.

VCR has attracted many research and development efforts from both OEMs and suppliers for a long time. Various approaches have been proposed,

including moving the cylinder heads, varying the geometry of the connecting rod, moving the crankshaft axis, or changing piston deck height.

FEV proposed a two-stage VCR system, enabled by varying the length of the connecting rod between discrete high and low points. This system requires only minor modifications to the connecting rods and the crankshaft, according to FEV. The cost of this system would thus be significantly lower than that of a continuous VCR system while retaining 80% of the potential reduction in fuel consumption (FEV GmbH, 2015). FEV also estimated this system would reduce fuel use by 4.2%-6.2% on the U.S. combined cycles (Kleeberg, Tomazic, Dohmen, Wittek, and Balazs, 2013).

Nissan put the first VCR system into production in 2018 on Infiniti models. Its variable compression ratio turbocharging system (VC-T) uses a multi-link system to raise or lower the reach of the pistons, allowing the compression ratio to vary continuously between 8:1 and 14:1 (Nissan, 2016). Nissan unveiled the 2.0L I4 VC-T engine at the 2016 Paris Motor Show. The engine first appeared in Infiniti’s QX50 in MY2019, replacing a 3.5L V6 engine. This resulted in a weight reduction of 25kg and a fuel-consumption reduction of 27%, compared with the V6 predecessor, according to Nissan (Kendall, 2016). However, this improvement in fuel efficiency was not entirely due to the implementation of VCR as other efficiency technologies, such as Miller cycle and turbo-downsizing, were also applied.

**4.6 WATER INJECTION**

Apart from cooled EGR, water injection offers an alternative technology for reducing the risk of knocking,

thus enabling higher compression ratio through charge cooling by the evaporation of water in the engine’s cylinders. It also increases fuel efficiency by reducing heat losses and fuel enrichment, and allows the engine to operate with higher boost and earlier spark timing, resulting in greater power and torque.

As a performance enhancement technology, water injection was used during World War II in reciprocating aircraft engines. The first application of this technology in a limited-production vehicle was by BMW in the M4 GTS (BMW, 2015). Recent studies have explored its potential for reducing fuel consumption as a function of the location of water injection and the amount of water injected over a broad range of engine operating conditions. Broadly, these studies point to a 13%-20% reduction in fuel consumption at high loads (Pauer et al., 2016; Kim, Park, Bae, Choi, and Kwak, 2016) and a 4%-6% reduction over an entire drive cycle (NEDC or WLTP) (Hoppe, Thewes, Baumgarten, and Dohmen, 2016; Thewes et al., 2016).

Water injection has ideal synergies with VCR and cooled EGR technologies. VCR can compensate for higher knock limitations with a lower compression ratio if water injection cannot be used due to a lack of water or at low ambient temperatures. At the same time, high compression ratio can be maintained up to the highest loads if water injection is possible. Cooled EGR allows a deep reduction in the amount of injected water (Thewes et al., 2016).

Reflecting the potential benefits for reducing fuel consumption and improving engine performance, water injection has been investigated extensively over the past few years. However, significant problems need to be resolved before this technology can become widely

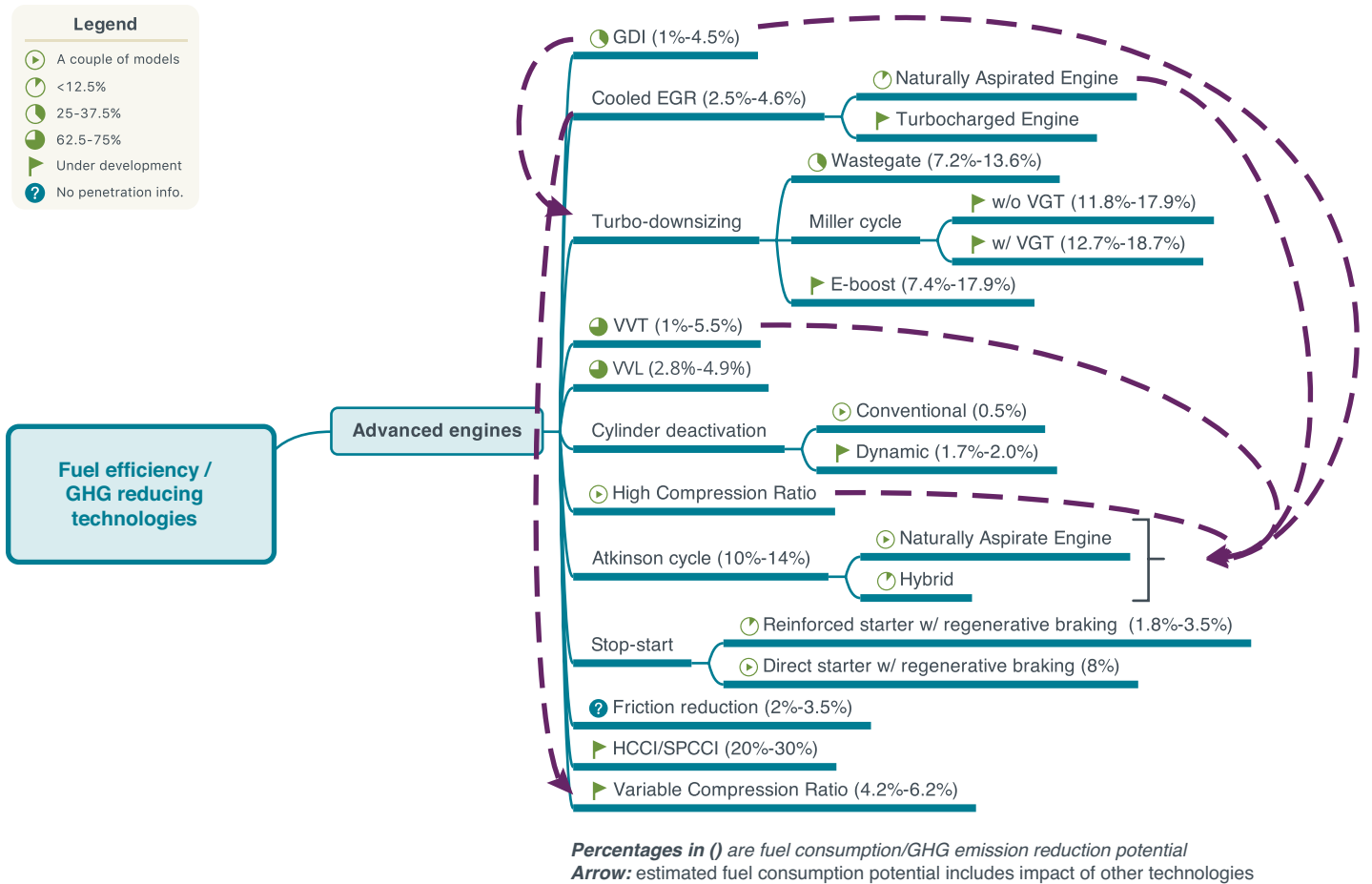

**Figure 10** Advanced engine technology map for passenger cars in China

adopted. From a cost-of-ownership perspective, the most significant obstacle is the rather large amount of on-board water required. Most studies indicate an optimum water-to-fuel ratio of 30%-50%, which translates to 2.4- 3.9L/100 km of water consumption for a vehicle with fuel efficiency of 7.8 L/100km. This would require filling up a 10L water tank at roughly every other fuel stop. One option could be on-board recovery of water, which researchers are investigating. Other considerations are the cost of additional hardware, pressure drop, size limitations, complexities for engine management, purity of water, and consumer acceptance.

### 5 Summary

Figure 10 summarizes the key technologies explored in this paper. The adoption status of each technology in the China market is indicated before the name of each technology. The pie charts reflect the latest market penetration of commercialized technologies in China. VVT, VVL, GDI, and turbo-downsizing have relatively higher penetration. The start signs represent emerging technologies that appear on a couple of models, such as conventional DEAC, direct start, and Atkinson cycle. The green flags represent underdeveloped technologies that have been applied or researched in other countries but still under development in

China. The blue question mark for friction reduction technology indicates a lack of information on market penetration. Water injection is not included because the technology is still at an early stage of research and development.

The percentages following each technology summarize its potential for reducing fuel consumption. In most cases, the reduction potential is compared with baseline vehicles without only the technology under study. For some technologies, the impact on fuel consumption is provided in combination with other technologies that are difficult to isolate. In those cases, arrows indicate which technologies are included in fuel-consumption



reduction estimates. For example, the application of Atkinson cycle is always combined with GDI, cooled EGR, VVT, and high compression ratio, so its impact on fuel consumption includes the effect of all the included technologies. The percentage ranges represent the average impact.

Based on the application status of advanced engine technologies in China, we group the technologies into three categories:

**Commercialized technologies.** Technologies that are already adopted at least on several production models in China and could be applied widely through the fleet.

**Emerging technologies.** Technologies that are available on passenger cars sold in the Chinese market but are available on only a couple of models, such as variants of flagship autos

**Table 2** Advanced engine technologies at different development stages in China

Commercialized technologies	Emerging technologies	Underdeveloped technologies
<ul style="list-style-type: none"> <li>• GDI</li> <li>• Cooled EGR for (NA engine)</li> <li>• Turbocharger (waste gate)</li> <li>• VVT</li> <li>• VVL</li> <li>• Atkinson cycle (hybrid)</li> <li>• Reinforced starter</li> <li>• Friction reduction</li> </ul>	<ul style="list-style-type: none"> <li>• Conventional cylinder deactivation</li> <li>• High compression ratio</li> <li>• Atkinson cycle (NA engine)</li> <li>• Direct starter</li> </ul>	<ul style="list-style-type: none"> <li>• Cooled EGR (Turbo)</li> <li>• Miller cycle</li> <li>• E-boost</li> <li>• Dynamic cylinder deactivation</li> <li>• HCCI/SPCCI</li> <li>• Variable compression ratio</li> </ul>

or luxury vehicles targeting high-end users.

**Underdeveloped technologies.** Technologies that have been adopted in other markets but currently are not available on cars produced in China, or technologies that have been announced by manufacturers or suppliers and are likely to be adopted

on production passenger cars in the near future.

Table 2 lists the advanced engine technologies under each category based on our definitions. This information will be used for estimating fuel-saving potential of all efficiency technologies in the summary paper of this series of working papers.

## References

- Ashley, S. (2010, October 7). Inside Fiat's innovative MultiAir system. *SAE International*
- Birch S. (2015, June 17). Ford tests cylinder deactivation on its 1.0-L EcoBoost triple. *Automotive Engineering, SAE International*. Retrieved from <https://www.sae.org/news/2015/06/ford-tests-cylinder-deactivation-on-its-1-0-l-ecoboost-triple>
- Birch S. (2017, June 16). Delphi and Tula show NVH benefits from Dynamic Skip Fire. *Automotive Engineering, SAE International*. Retrieved from <https://www.sae.org/news/2017/06/delphi-and-tula-show-nvh-benefits-from-dynamic-skip-fire>
- BMW. (2015). 5 Liters of Water for 500 Horses. *BMW M Magazine*. Retrieved from <https://www.bmw-m.com/en/topics/magazine-article-pool/5-litres-of-water-for-500-horses.html>
- Boeriu, H. (2016). What is Valvetronic? BMW's innovative throttle system. *BMWBlog*. Retrieved from <http://www.bmwblog.com/2016/07/25/valvetronic-bmws-innovative-throttle-system/>
- China Automotive Technology and Research Center (CATARC). (2017). 中国乘用车中长期节能潜力与路径研究[*Research on China passenger car medium and long-term energy saving potential and path*]. Retrieved from <http://www.efchina.org/Reports-zh/report-20170919-1-zh>
- Chery. (2017, June 10). Rivaling world advanced level, Chery 3<sup>rd</sup> generation high-performance engine off-line. Retrieved from <http://www.cheryinternational.com/news/20170610265.html>
- Chi, D. (2016). 长安Blue Core 1.5TDPI 发动机浅析 [A brief analysis of the all new Chang'an Blue Core 1.5TDPI engine]. *PCauto*. Retrieved from [www.pcauto.com.cn/tech/809/8090868.html](http://www.pcauto.com.cn/tech/809/8090868.html)
- Delphi. (2015) Dynamic Skip Fire. Retrieved from <https://www.delphi.com/dynamic-skip-fire-1>
- Environmental Protection Agency (EPA). (2016a). Proposed determination on the appropriateness of the model year 2022-2025 light-duty vehicle greenhouse gas emissions standards under the midterm evaluation. *81 Fed. Reg. 87,927 (Notice of proposed order published Dec. 6, 2016)*. Retrieved from <https://www.federalregister.gov/documents/2016/12/06/2016-29255/proposed-determination-on-the-appropriateness-of-the-model-year-2022-2025-light-duty-vehicle>
- EPA. (2016b). Light-duty automotive technology, carbon dioxide emissions, and fuel economy trends: 1975 through 2016. *EPA-420-R-16-010*. Retrieved from <https://www.epa.gov/fuel-economy/trends-report>
- EPA. (2017). Light-duty automotive technology, carbon dioxide emissions, and fuel economy trends: 1975 through 2017. *EPA-420-R-18-001*. Retrieved from <https://nepis.epa.gov/Exe/ZyPDF.cgi?Dockkey=P100TGDW.pdf>
- EPA & National Highway Traffic Safety Administration (NHTSA). (2012). Joint Technical Support Document: Final Rulemaking for 2017-2025 Light-duty Vehicle Greenhouse Gas Emission Standards and Corporate Average Fuel Economy Standards. *EPA-420-R-12-901*. Retrieved from <https://www3.epa.gov/otaq/climate/regs-light-duty.htm#2017-2015>
- Federal-Mogul. (2016). New Federal-Mogul Powertrain piston skirt coatings increase durability for the life of pistons. Available at <http://investor.federalmogul.com/phoenix.zhtml?c=97066&p=irol-newsArticle&ID=2151717#.Ws71RNNu-ZUc> and <http://www.federalmogul.com/en-US/OE/Products/Pages/Product-Details.aspx?CategoryId=40&SubCategoryId=200&ProductId=217>
- FEV GmbH. (2015). 2025 Passenger Car and Light Commercial Vehicle Powertrain Technology Analysis. Retrieved from the International Council on Clean Transportation, <https://www.theicct.org/publications/2025-passenger-car-and-light-commercial-vehicle-powertrain-technology-analysis>
- Fischer, M., Kreuziger, P., Sun, Y., & Kotrba, A. (2017). *Clean EGR for Gasoline Engines—Innovative Approach to Efficiency Improvement and Emissions Reduction Simultaneously*. (Technical Paper 2017-01-0683). Retrieved from SAE International, <https://saemobilus.sae.org/content/2017-01-0683>
- German, J. (2015). *Hybrid vehicles: Trends in technology development and cost reduction*. Retrieved from the International Council on Clean Transportation, <https://www.theicct.org/publications/hybrid-vehicles-trends-technology-development-and-cost-reduction>
- German, J. (2018). *How things work: OMEGA modeling case study based on the 2018 Toyota Camry*. Retrieved from the International Council on Clean Transportation, <https://www.theicct.org/publications/how-things-work-omega-modeling-case-study-based-2018-toyota-camry>
- Hoppe, F., Thewes, M., Baumgarten, H., & Dohmen, J. (2016). Water injection for gasoline engines: Potentials, challenges, and solutions. *International Journal of Engine Research* 17(1): 86-96. Retrieved from <http://journals.sagepub.com/doi/abs/10.1177/1468087415599867>
- Isenstadt, A., German, J., & Dorobantu, M. (2016). *Naturally aspirated gasoline engines and cylinder deactivation*. Retrieved from the International Council on Clean Transportation, <http://www.theicct.org/naturally-aspirated-gas-engines-201606>
- Isenstadt, A., German, J., Dorobantu, M., Boggs, D., & Watson, T. (2016). *Downsized, boosted gasoline engines*. Retrieved from the International Council on Clean Transportation, <http://www.theicct.org/downsized-boosted-gasoline-engines>
- Kendall, J. (2016, October 3). Nissan unveils 2018 production variable-compression-ratio ICE. *Automotive Engineering, SAE International*. Retrieved from <https://www.sae.org/news/2016/10/nissan-unveils-2018-production-variable-compression-ratio-ice>

- Kim, J., Park, H., Bae, C., Choi, M., & Kwak, Y. (2016). Effects of Water Direct Injection on the Torque Enhancement and Fuel Consumption Reduction of a Gasoline Engine Under High-Load Conditions. *International Journal of Engine Research* 17(7): 795-808. Retrieved from <http://journals.sagepub.com/doi/abs/10.1177/1468087415613221>
- Kleeberg, H., Tomazic, D., Dohmen, J., Wittek, K., & Balazs, A. (2013). *Increasing Efficiency in Gasoline Powertrains with a Two-Stage Variable Compression Ratio (VCR) System*. (SAE Technical Paper 2013-01-0288). Retrieved from SAE Mobilus, SAE International <https://saemobilus.sae.org/content/2013-01-0288>
- Li, M. (2018, January 27). 中国工况项目介绍 [Introduction to CATC]. *Gasgoo*. Retrieved from <http://auto.gasgoo.com/News/2018/01/21013544354470032638C501.shtml>
- Li. (2013). China turbocharger sales will achieve 10 million by 2018- Honeywell latest estimates. *Technology and market. Automobile and Parts. APM(No.8) 2013-33*
- Lutsey, N., Meszler, D., Isenstadt, A., German, J., & Miller, J. (2017). *Efficiency Technology and Cost Assessment for U.S. 2015-2030 Light-duty Vehicles*. Retrieved from the International Council on Clean Transportation, <https://www.theicct.org/publications/US-2030-technology-cost-assessment>
- Mazda. (2009). Idling Stop Technology. Retrieved from <http://www.mazda.com/en/innovation/technology/env/i-stop/>
- Mazda. (2010). Mazda Reveals Next-Generation 'SKYACTIV' Technologies. Retrieved from <http://www2.mazda.com/en/publicity/release/2010/201010/101020a.html>
- Mazda. (2011). Mazda 'i-ELOOP' Capacitor-Based Brake Energy Regeneration System. Retrieved from <http://www2.mazda.com/en/publicity/release/2011/201111/111125a.html>
- Mazda. (2016). All-new CX-9 features new SKYACTIV-G 2.5 L, Direct-injection, Turbo-charged Engine. Retrieved from <https://www.mazda.ca/en/inside-mazda/engine/>
- Mazda. (2017). SKYACTIV-X: a revolutionary new combustion engine. Retrieved from <http://www.mazda.com/en/innovation/mazda-stories/engineers/skyactiv-x/>
- Ministry of Industry and Information Technology (MIIT). (2015, May 22). 《中国制造2025》解读之：推动节能与新能源汽车发展 [Interpreting "Made in China 2025": promoting development of energy saving and new energy vehicles]. Available at <http://www.miit.gov.cn/n973401/n1234620/n1234623/c3843796/content.html>
- Morey B. (2014, September 17). Cooled EGR shows benefits for gasoline engines. *Automotive Engineering. SAE International*. Retrieved from <https://www.sae.org/news/2014/09/cooled-egr-shows-benefits-for-gasoline-engines>
- Nissan. (2006). VQ35HR Engine/VQ25HR Engine. Retrieved from [https://www.nissan-global.com/EN/DOCUMENT/PDF/TECHNOLOGY/TECHNICAL/VQ35HR\\_EN.pdf](https://www.nissan-global.com/EN/DOCUMENT/PDF/TECHNOLOGY/TECHNICAL/VQ35HR_EN.pdf)
- Nissan. (2008). Variable Valve Event and Lift system (VVEL). Retrieved from [https://www.nissan-global.com/EN/DOCUMENT/PDF/TECHNOLOGY/TECHNICAL/VVEL\\_EN.pdf](https://www.nissan-global.com/EN/DOCUMENT/PDF/TECHNOLOGY/TECHNICAL/VVEL_EN.pdf)
- Nissan. (2016). Infiniti VC-Turbo: The world's first production-ready variable compression ratio engine. Retrieved from <https://newsroom.nissan-global.com/releases/infiniti-vc-t-the-worlds-frst-production-ready-variable-compression-ratio-engine>
- Pauer, T., Frohnmaier, M., Walther, J., Schenk, P., Hettinger, A., & Kampmann, S. (2016). *Optimization of Gasoline Engines by Water Injection*. Presented at the 37th International Vienna Motor Symposium.
- Pohorelsky, L., Vondrak, A., Chobola, P., Jeckel, D., & Davies, P. (2018). *RDE and CO2 Relevant Boosting Technologies for passenger cars*. Retrieved from Honeywell <https://turbo.honeywell.com/whats-new-in-turbo/technical-papers/>
- Society of Automotive Engineers of China (SAE China). (2017). 《节能与新能源汽车技术路线图》 [Energy-saving and new energy vehicle technology roadmap]. *China Machine Press*.
- Schenk, C. and Dekraker, P. (2016). *Potential fuel economy improvements from the implementation of cEGR and CDA on an Atkinson Cycle Engine*. (SAE Technical Paper 2017-01-1016). SAE International. Retrieved from <https://www.sae.org/publications/technical-papers/content/2017-01-1016/>
- Sun, S. (2017, July 14). ZMJ disclosure the business details of purchasing Bosch SG. *Economic Information Daily*. Retrieved from [http://jckb.xinhuanet.com/2017-07/14/c\\_136442878.htm](http://jckb.xinhuanet.com/2017-07/14/c_136442878.htm)
- Takahashi, D., Nakata, K., Yoshihara, Y., Ohta, Y., & Nishiura, H. (2015). *Combustion Development to Achieve Engine Thermal Efficiency of 40% for Hybrid Vehicles*. (SAE Technical Paper 2015-01-1254). SAE International. Retrieved from <https://saemobilus.sae.org/content/2015-01-1254>
- Thewes, M., Baumgarten, H., Scharf, J., Birmes, G., Balazs, A., Lehrheuer, B., & Hoppe, F. (2016). *Water Injection—High Power and High Efficiency Combined*. Presented at the 25th Aachen Colloquium Automobile and Engine Technology. Retrieved from [https://www.researchgate.net/publication/309180012\\_Water\\_Injection\\_-\\_High\\_Power\\_and\\_High\\_Efficiency\\_Combined](https://www.researchgate.net/publication/309180012_Water_Injection_-_High_Power_and_High_Efficiency_Combined)
- Toyota. (2016). New 2.5-liter Direct-injection, Inline 4-cylinder Gasoline Engine. Retrieved from <https://newsroom.toyota.co.jp/en/powertrain/engine/>
- Toyota. (2018). 2.0-liter Dynamic Force Engine, a New 2.0-liter Direct-injection, Inline 4-cylinder Gasoline Engine. Retrieved from <https://newsroom.toyota.co.jp/en/powertrain2018/engine/>
- Tula. (2015). How dynamic skip fire (DSF) works. Retrieved from <https://www.tulatech.com/dsf-overview/>

- Volkswagen. (2016). Volkswagen at the 37<sup>th</sup> Vienna Motor Symposium. Retrieved from [https://www.volkswagen-media-services.com/en/detailpage/-/detail/Volkswagen-at-the-37th-Vienna-Motor-Symposium/view/3451577/5f5a4dcc90111ee56bcca439f2dcc518?p\\_p\\_auth=M2yfp3Ze](https://www.volkswagen-media-services.com/en/detailpage/-/detail/Volkswagen-at-the-37th-Vienna-Motor-Symposium/view/3451577/5f5a4dcc90111ee56bcca439f2dcc518?p_p_auth=M2yfp3Ze)
- Wang, T., Huang, Y., & Huang, Y. (2016). Optimization study of fuel consumption of an engine. *Small Internal Combustion Engine and Vehicle Technique 2016*. 45(4): 23-25.
- Wolfram, P., & Lutsey, N. (2016). *Electric vehicles: Literature review of technology costs and carbon emissions*. Retrieved from the International Council on Clean Transportation, <https://www.theicct.org/lit-review-ev-tech-costs-co2-emissions-2016>
- Zhao, D., Wang, H., Qu, R., & Ren, H. (2015). Trend analysis of 48V vehicle electric system idling stop-start technology application. *Auto Industry Research 2015(10)*: 41-47.
- Zhen, S. (2015). BorgWarner Advanced Gasoline EGR Technology. Retrieved from <https://wenku.baidu.com/view/6993c917783e0912a3162a28.html>
- Zheng, J., Zhan, Z., Shen, H., Li, X., Xu, Z., Tang, Y., Chen, X., Zeng, Q., Qing, H., & Hu, T. (2016). *Simulation guided design for developing direct injection combustion systems of gasoline engines*. (SAE Technical Paper 2016-01-2313). SAE International. Retrieved from <https://saemobilus.sae.org/content/2016-01-2313>
- Zhou C. (2014, October 8). 博格华纳汽油机EGR让发动机更高效 [BorgWarner's Gasoline EGR makes engine more efficient]. *Gasgoo*. Retrieved from <http://auto.gasgoo.com/News/2014/10/0811170017060312853358.shtml>
- Zhou, H., & Yang, Z. (2018). *The new passenger car fleet in China, 2014: technology assessment and comparison, 2014 versus 2010*. Retrieved from the International Council on Clean Transportation, <https://www.theicct.org/publications/new-passenger-car-fleet-china-2014-technology-assessment-and-comparison-2014-versus>